



M18 Metal Barrel-Mount Sensors

Epoxy-encapsulated metal barrel sensors provide reliable sensing without adjustments.

- Available in multiple operating modes
- Meets IP69K standards
- Wide operating range from -40° C to +70° C
- High performance sensing
- Cordsets and brackets see page 200

Opposed M18, 10-30 V DC

 Infrared LED

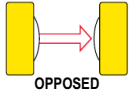

 Visible Red LED

Sensing Mode	Range	Connection	Models NPN	Models PNP
 <p>OPPOSED</p>	20 m	2 m		M186E Emitter
		4-pin Euro QD		M186EQ Emitter
		2 m	M18SN6R	M18SP6R
		4-pin Euro QD	M18SN6RQ	M18SP6RQ

Retro & Polar Retro M18, 10-30 V DC

 Infrared LED

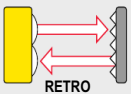
 Visible Red LED

Sensing Mode	Range	Connection	Models NPN	Models PNP
 <p>RETRO</p>	2 m [†]	2 m	M18SN6L	M18SP6L
		4-pin Euro QD	M18SN6LQ	M18SP6LQ
 <p>POLAR RETRO</p>	2 m [†]	2 m	M18SN6LP	M18SP6LP
		4-pin Euro QD	M18SN6LPQ	M18SP6LPQ

For more specifications see page 203.

 **Connection options:** A model with a QD requires a mating cordset (see page 200).

For 9 m cable, add suffix **W/30** to the 2 m model number (example, **M18SP6D W/30**).

[†] Retroreflective range is specified using one model BRT-3 retroreflector, unless otherwise noted.
Actual sensing range may differ, depending on the efficiency and reflective area of the retroreflector used. See Accessories section for more information.

Diffuse M18, 10-30 V DC

 Infrared LED

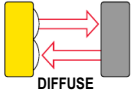
Sensing Mode	Range	Connection	Models NPN	Models PNP
	100 mm	2 m	M18SN6D	M18SP6D
		4-pin Euro QD	M18SN6DQ	M18SP6DQ
	300 mm	2 m	M18SN6DL	M18SP6DL
		4-pin Euro QD	M18SN6DLQ	M18SP6DLQ

Fixed-Field M18, 10-30 V DC

 Infrared LED

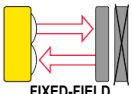
Sensing Mode	Range	Connection	Models NPN	Models PNP
	0 - 25 mm Cutoff	2 m	M18SN6FF25	M18SP6FF25
		4-pin Euro QD	M18SN6FF25Q	M18SP6FF25Q
	0 - 50 mm Cutoff	2 m	M18SN6FF50	M18SP6FF50
		4-pin Euro QD	M18SN6FF50Q	M18SP6FF50Q
	0 - 100 mm Cutoff	2 m	M18SN6FF100	M18SP6FF100
		4-pin Euro QD	M18SN6FF100Q	M18SP6FF100Q







For more specifications see page 203.

 **Connection options:** A model with a QD requires a mating cordset (see page 200).
For 9 m cable, add suffix **W30** to the 2 m model number (example, **M18SP6D W30**).

Cordsets







Euro QD (for Q models)

See page 906

Length	Threaded 4-Pin	
	Straight	Right-Angle
1.83 m	 MQDC-406	 MQDC-406RA
4.57 m	 MQDC-415	 MQDC-415RA
9.14 m	 MQDC-430	 MQDC-430RA

Micro QD (for Q1 models)

See page 919

Length	Threaded 4-Pin	
	Straight	Right-Angle
1.83 m	 MQAC-406	 MQAC-406RA
4.57 m	 MQAC-415	 MQAC-415RA
9.14 m	 MQAC-430	 MQAC-430RA

 Additional cordset information available. See page 902.

Brackets





M18 & S18

See page 864

See page 864

See page 866

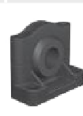
See page 868

			
SMB18FA..	SMB18A	SMB3018SC	SMBAMS18P

 Additional brackets and information available. See page 852.

Other Accessories

Reflectors

See page 932

Apertures

See page 958



S18-2 dc Polarized Retroreflective and Fixed-Field Models
Suffix LP and FF



S18 dc Opposed, Non-polarized Retroreflective and Diffuse Models
Suffix E, R, L and D





S18 ac Opposed, Retroreflective, Polarized Retroreflective, Diffuse and Fixed-Field Models
Suffix E, R, L, LP, D and FF





M18 Opposed, Non-polarized Retroreflective and Diffuse Models
Suffix E, R, L, D and DL

S18-2 and S18 DC Specifications

Supply Voltage and Current	<p>S18: 10 to 30 V dc (10% max. ripple); Supply current (exclusive of load current):</p> <p>S18-2: 10 to 30 V dc $\leq 55^{\circ}$ C; 10 to 24 V dc $> 55^{\circ}$ C (10% max. ripple); Supply current (exclusive of load current):</p> <p>S18-2: Opposed Emitters: 17 mA S18: Opposed Emitters: 25 mA Opposed Receivers: 8 mA Opposed Receivers: 20 mA Polarized Retroreflective: 16 mA Polarized Retroreflective: 30 mA Diffuse: 16 mA Non-polarized Retroreflective: 25 mA Fixed-Field: 35 mA Diffuse: 25 mA</p>
Supply Protection Circuitry	Protected against reverse polarity and transient voltages
Output Configuration	Solid-state complementary dc switch; NPN (current sinking) or PNP (current sourcing), depending on model S18: The Dark Operate (DO) output may be wired as a normally open marginal signal alarm output, depending upon hookup to the power supply
Output Rating	<p>S18: 150 mA max. (each) in standard hookup. When wired for alarm output, the total load may not exceed 150 mA</p> <p>S18-2: Less than or equal to 100 mA total current through both outputs at less than or at 55° C Less than or equal to 50 mA total current for ambient temperatures greater than 55° C</p> <p>OFF-state leakage current: S18-2: less than 50 μA at 30 V dc S18: less than 1 μA at 30 V dc</p> <p>ON-state saturation voltage: S18-2: less than 1.5 V at 10 mA dc; less than 2.75 V at 100 mA dc S18: less than 1 V at 10 mA dc; less than 1.5 V at 150 mA dc</p>
Output Protection Circuitry	Protected against false pulse on power-up and continuous overload or short circuit of outputs
Output Response Time	<p>S18-2: Opposed: 1.5 milliseconds ON, 1.0 milliseconds OFF Retro, Polarized Retroreflective and Diffuse: 1.5 milliseconds ON, 0.75 milliseconds OFF</p> <p>S18: Opposed: 3 milliseconds ON, 1.5 milliseconds OFF Polarized Retroreflective, Non-polarized Retroreflective, Fixed-Field and Diffuse: 3 milliseconds ON/OFF</p>
Delay at Power-up	100 milliseconds; outputs are non-conducting during this time
Repeatability	<p>S18-2: Opposed: 170 microseconds Polarized Retroreflective and Diffuse: 100 microseconds</p> <p>S18: Opposed: 375 microseconds Polarized Retroreflective, Non-polarized Retroreflective, Fixed-Field and Diffuse: 750 microseconds. Repeatability and response are independent of signal strength.</p>
Adjustments	Diffuse (DL), Emitter (ES), Receiver (RS), Polarized Retroreflective (LPC), Retroreflective (LV) models: Single turn sensitivity (gain) adjustment potentiometer Emitter Beam Inhibit (EJ) models: Tie black wire to 10 to 30 V dc for beam inhibit
Indicators	<p>S18-2: Three LED's: Green: Power is ON Green Flashing: Marginal sensing signal Yellow: Pin 4 (black wire) output conducting</p> <p>S18: Two LEDs: Green: Power is ON Green Flashing: Output overloaded Yellow: Light Operate (LO) output is energized</p>
Construction	<p>S18-2 models: ABS housing</p> <p>S18 models: thermoplastic polyester housing</p> <p>Lenses are polycarbonate or acrylic; S18 models come with two jam nuts</p>
Environmental Rating	<p>S18-2: IEC 60529 IP67</p> <p>S18: Leakproof design rated NEMA 6P, IP67. QD models rated IP69K per DIN 40050-9.</p>
Connections	2 m or 9 m attached cable, or 4-pin Euro-style quick-disconnect fitting. QD cordsets are ordered separately. See page 200.
Operating Conditions	Temperature: -40° to $+70^{\circ}$ C Relative humidity: S18: 90% at 50° C (non-condensing) S18-2: 95% @ 50° C (non-condensing)
Vibration and Mechanical Shock	All models meet Mil. Std. 202F requirements. Method 201A (Vibration; frequency 10 to 60 Hz, max., double amplitude 0.06-inch acceleration 10G). Method 213B conditions H&I (Shock: 75G with unit operating; 100G for non-operation)
Certifications	<p>S18-2, S18 models:  S18 models:   ECOLAB® chemical compatibility pending on some models; contact Banner Engineering for details</p>

S18 AC Specifications

Supply Voltage and Current	20 to 250 V ac (50/60 Hz). Average current: 20 mA. Peak current: 200 mA at 20 V ac, 500 mA at 120 V ac, 750 mA at 250 V ac
Supply Protection Circuitry	Protected against transient voltages
Output Configuration	Solid-state ac switch; three-wire hookup; Light Operate (LO) or Dark Operate (DO), depending on model Light Operate: Output conducts when the sensor sees its own (or the emitter's) modulated light Dark Operate: Output conducts when sensor sees dark
Output Rating	300 mA max. (continuous) Fixed-Field: derate 5 mA/° C above +50° C Inrush capability: 1 amp for 20 milliseconds, non-repetitive OFF-state leakage current: less than 100 µA ON-state voltage drop: 3 V at 300 mA ac; 2 V at 15 mA ac
Output Protection Circuitry	Protected against false pulse on power-up
Output Response Time	Opposed: 16 milliseconds ON, 8 milliseconds OFF Polarized Retroreflective, Non-polarized Retroreflective, Fixed-Field and Diffuse: 16 milliseconds ON/OFF
Delay at Power-up	100 milliseconds
Repeatability	Opposed: 2 milliseconds Polarized Retroreflective, Non-polarized Retroreflective, Fixed-Field and Diffuse: 4 milliseconds Repeatability and response are independent of signal strength.
Indicators	Two LEDs: Green: Power ON Yellow: Light sensed Yellow Flashing: Marginal excess gain
Construction	Housings are thermoplastic polyester. Lenses are polycarbonate or acrylic; two jam nuts included.
Environmental Rating	Leakproof design rated NEMA 6P, IP67. QD models rated IP69K per DIN 40050-9.
Connections	2 m or 9 m attached cable, or 4-pin Micro-style quick-disconnect fitting. QD cordsets are ordered separately. See page 200.
Operating Conditions	Temperature: -40° to +70° C Relative humidity: 90% at 50° C (non-condensing)
Vibration and Mechanical Shock	All models meet Mil. Std. 202F requirements. Method 201A (Vibration; frequency 10 to 60 Hz, max, double amplitude 0.06-inch acceleration 10G). Method 213B conditions H&I (Shock: 75G with unit operating; 100G for non-operation)
Certifications	   ECOLAB® chemical compatibility pending on some models; contact Banner Engineering for details

M18 DC Specifications

Supply Voltage and Current	10 to 30 V dc (10% max. ripple); Supply current (exclusive of load current): Opposed Emitters: 25 mA Polarized Retroreflective: 30 mA Fixed-Field: 35 mA Opposed Receivers: 20 mA Non-polarized Retroreflective: 25 mA Diffuse: 25 mA
Supply Protection Circuitry	Protected against reverse polarity and transient voltages
Output Configuration	Solid-state complementary dc switch; NPN (current sinking) or PNP (current sourcing), depending on model The Dark Operate (DO) output may be wired as a normally open marginal signal alarm output, depending upon hookup to the power supply
Output Rating	150 mA max. (each) in standard hookup. When wired for alarm output, the total load may not exceed 150 mA OFF-state leakage current: less than 1 μ A at 30 V dc ON-state saturation voltage: less than 1 V at 10 mA dc; less than 1.5 V at 150 mA dc
Output Protection Circuitry	Protected against false pulse on power-up and continuous overload or short circuit of outputs
Output Response Time	Opposed: 3 milliseconds ON, 1.5 milliseconds OFF Polarized Retroreflective, Non-polarized Retroreflective, Fixed-Field and Diffuse: 3 milliseconds ON/OFF
Delay at Power-up	100 milliseconds; outputs are non-conducting during this time
Repeatability	Opposed: 375 microseconds Polarized Retroreflective, Non-polarized Retroreflective, Fixed-Field and Diffuse: 750 microseconds. Repeatability and response are independent of signal strength.
Indicators	Two LEDs: Green: Power is ON Green Flashing: Output overloaded Yellow: Light Operate (LO) output is energized Yellow Flashing: Marginal excess gain
Construction	Stainless steel housing Lenses are polycarbonate or acrylic; come with two jam nuts
Environmental Rating	Leakproof design rated NEMA 6P, IP67. QD models rated IP69K per DIN 40050-9.
Connections	2 m or 9 m attached cable, or 4-pin Euro-style quick-disconnect fitting. QD cordsets are ordered separately. See page 200.
Operating Conditions	Temperature: -40° to +70° C Relative humidity: 90% at 50° C (non-condensing)
Vibration and Mechanical Shock	All models meet Mil. Std. 202F requirements. Method 201A (Vibration; frequency 10 to 60 Hz, max., double amplitude 0.06-inch acceleration 10G). Method 213B conditions H&I (Shock: 75G with unit operating; 100G for non-operation)
Certifications	M18 models: 

Excess Gain Curves (Diffuse and Fixed-Field mode performance based on 90% reflectance white test card[†])

○ = Infrared LED P = Visible Red LED Polarized

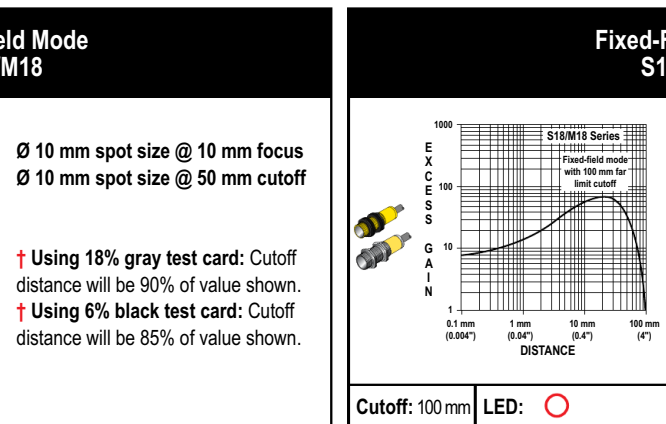
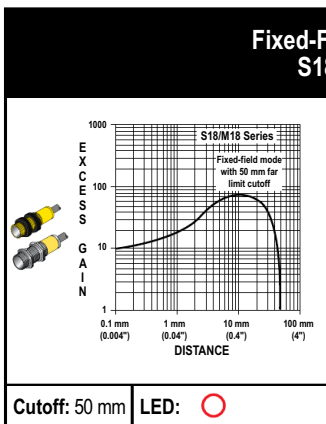
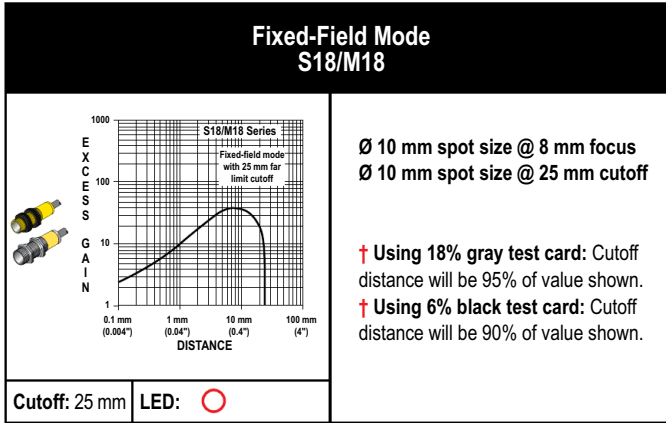
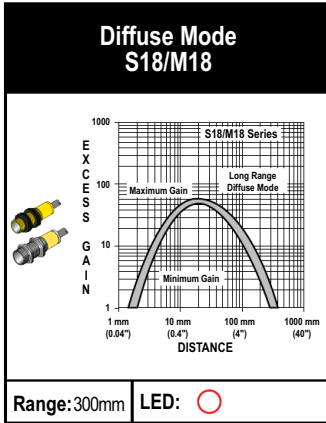
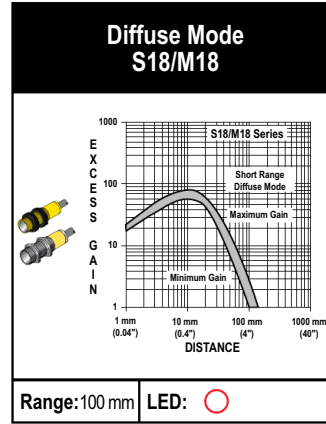
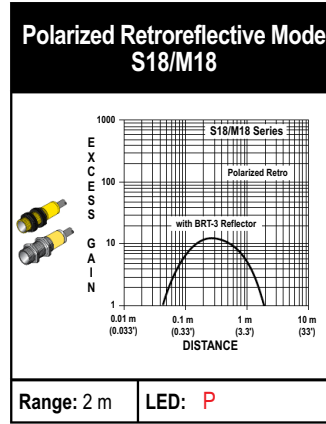
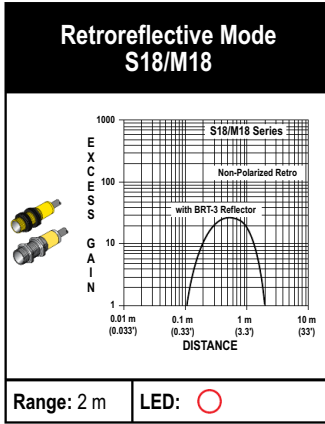
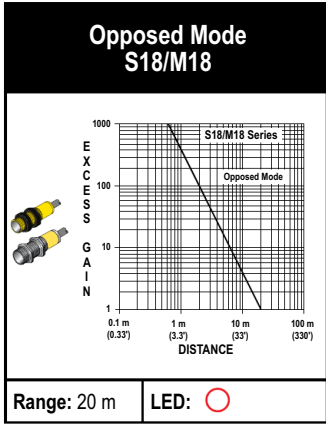

Beam Patterns (Diffuse mode performance based on 90% reflectance white test card)

○ = Infrared LED P = Visible Red LED Polarized

